



LIQUID FLOW SWITCHES

FUNCTION

Flow control of water and aggressive media (depending on model).
 Alarm signal of flow shortage.
 Available in brass, suitable for normal media, and in stainless steel AISI316L for aggressive media.

APPLICATIONS

Well-suited in pipes of general industrial plants:

- heating and air conditioning systems;
- refrigeration systems;
- heat pumps.

TYPE	PIPE Ø	MAX PRESSURE bar	NORMAL MEDIA (body in brass)	AGGRESSIVE MEDIA (body in stainless steel AISI 316L)	BODY WITH PIPE FITTING	PROTECTION	FLOW RATE
FS NBSF 1K	1...8"	11	•			IP65	1

Accessory	DBZ-09 - Stainless steel AISI 316L paddles for liquid flow switch
------------------	---

Notes: the flow switches are supplied with paddles model DBZ-09
 on request available 1" NPT connection version (product code "SFxx/NPT") for series SF1 and SF2

TECHNICAL DATA

Contacts: dust-tight microswitch with switching
 contacts SPDT

Switch capacity: 15 (8) A, 24...250 Vac

Working: -40...+85 °C
 10...90% r.h. (without condensing)

Max liquid temperature: -40...+120 °C

Max pressure: 11 bar (SF2: 30 bar)

Flow rate: see flow rate schedule 1-2-3

Connection: standard R1" (DIN 2999) for series SF1 and SF2

Body: see schedule above

Paddles: stainless steel AISI 316L

Housing: Base in ABS, transparent PC cover

Storage: -40...+85 °C
 < 95% r.h.

Protection: IP65, class I

Size: 140 x 62 x 65 mm

Weight: 950 g

LIQUID FLOW SWITCHES

①

H ₂ O FLOW RATE			
Pipe connector Ø	Q _{max} m ³ /h recommended	Min. adjustment m ³ /h cut-off (cut-in)	Max. adjustment m ³ /h cut-off (cut-in)
1"	3,6	0,6 (1,0)	2,0 (2,1)
1 1/4"	6,0	0,8 (1,3)	2,8 (3,0)
1 1/2"	9,0	1,1 (1,7)	3,7 (4,0)
2"	15,0	2,2 (3,1)	5,7 (6,1)
2 1/2"	24,0	2,7 (4,0)	6,5 (7,0)
3"	36,0	4,3 (6,2)	10,7 (11,4)
4"	60,0	11,4 (14,7)	27,7 (29,0)
4" Z	60,0	6,1 (8,0)	17,3 (18,4)
5"	94,0	22,9 (28,4)	53,3 (55,6)
5" Z	94,0	9,3 (12,9)	25,2 (26,8)
6"	120,0	35,9 (43,1)	81,7 (85,1)
6" Z	120,0	12,3 (16,8)	30,6 (32,7)
8"	240,0	72,6 (85,1)	165,7 (172,5)
8" Z	240,0	38,6 (46,5)	90,8 (94,2)

For models with suffix "Z" the longest paddle must be used to obtain the values indicated on the table.
Pressure drop at the maximum flow (Q_{max}): 0,08 bar

Note: the value indicated on schedule have been measured with the flow switch mounted on horizontal position.

Paddles (models without "T" pipe fitting)

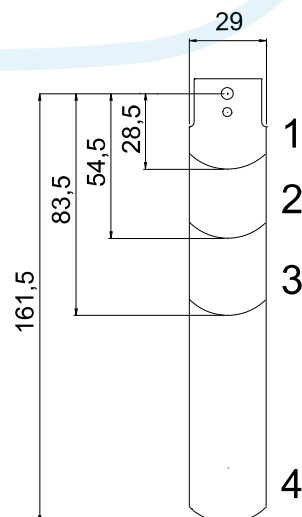

PIPE	PADDLES
1"	1
1 1/4"	1
1 1/2"	1
2"	1+2
2 1/2"	1+2
3"	1+2+3
4"	1+2+3
4" Z	1+2+3+4
5"	1+2+3
5" Z	1+2+3+4
6"	1+2+3
6" Z	1+2+3+4
8"	1+2+3
8" Z	1+2+3+4

LIQUID FLOW SWITCHES

WIRING DIAGRAM

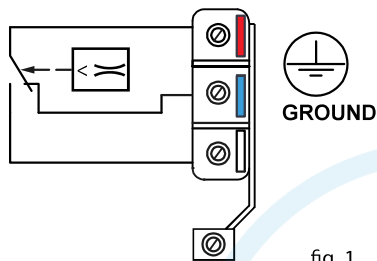

fig. 1

Connect to red and to white contacts of the microswitch (fig. 1). The contact red-white opens when the flow drops below the set level. When the flow is missing the contact red-blue closes and can be used as a signal or alarm contact.

INSTALLATION

The flowswitch can be installed in every position far from elbows or throttlings, with arrow on flow direction. If pipe is vertical, recalibrate range to balance paddle weight. If the device is downwards mounted take care to slugs, and apply it in a straight pipe far from filters, valves, etc with length at least 5 times the diameter of pipe upstream and downstream the unit.

NOTE

The flowswitch is factory calibrated at its min. sensitivity. To increase the set value turn clockwise the adjustment screw. The cut-out value must be $>$ the minimum flow necessary to guarantee the protection of the plant. The units without "T" fittings are supplied with 4 paddles, which must be cut off according to the pipe. All devices can be supplied with "T" connection on request as schedule indications.

ATTENTION

If flowswitch is used as a minimum flow controller, it is necessary to add another device downstream for alarm condition activation.

DIMENSIONS (mm)

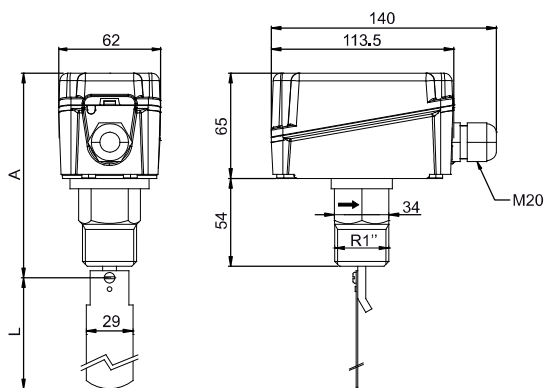

MOUNTING INSTRUCTIONS

