

■ ■ **Vanne à sphère Smart en laiton**

■ **Smart brass ball valve**

■ **Válvula de esfera Smart de latón**

**Art. 120**

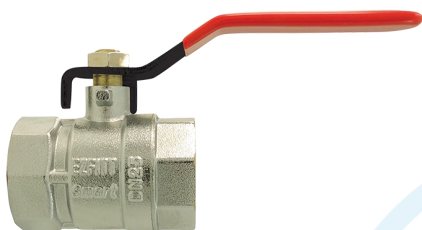

**F/F, poignée plate rouge**  
F/F, red flat handle  
H/H, palanca plana roja

**Art. 120 PB**

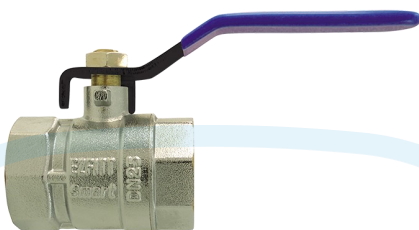

**F/F, poignée plate bleu**  
F/F, blue flat handle  
H/H, palanca plana azul

**Art. 123**

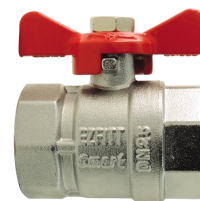

**F/F, poignée papillon rouge**  
F/F, red butterfly handle  
H/H, palanca mariposa roja

**Art. 121**

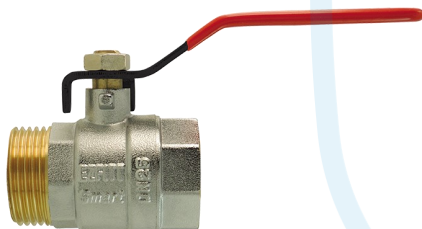

**M/F, poignée plate rouge**  
M/F, red flat handle  
M/H, palanca plana roja

**Art. 121 PB**

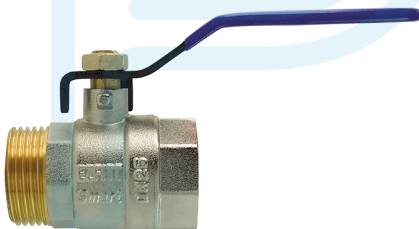

**M/F, poignée plate bleu**  
M/F, blue flat handle  
M/H, palanca plana azul

**Art. 124**



**M/F, poignée papillon rouge**  
M/F, red butterfly handle  
M/H, palanca mariposa roja

**Art. 122**

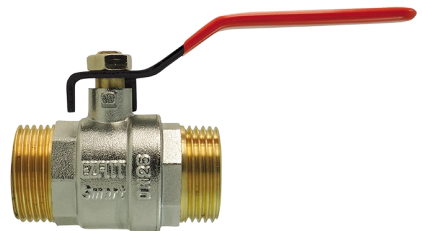

**M/M, poignée plate rouge**  
M/M, red flat handle  
M/M, palanca plana roja

**Art. 122 PB**

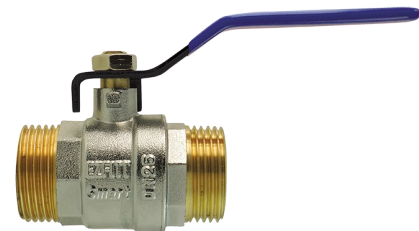

**M/M, poignée plate bleu**  
M/M, blue flat handle  
M/M, palanca plana azul

**Art. 125**

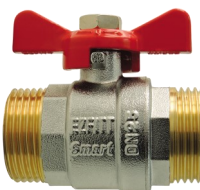

**M/M, poignée papillon rouge**  
M/M, red butterfly handle  
M/M, palanca mariposa roja

## Conditions d'utilisation

- Applications : Adduction d'eau potable, système de chauffage et climatisation, irrigation, industrie légère.
- Fluides : Eau, fluides non agressifs (compatibles EPDM / PTFE / laiton), air comprimé non lubrifié (8 bar maxi).
- Pression : PN32 / PN25 (selon la taille).
- Températures : -10°C / +120°C (+90°C en continu).

## Conditions of use

- Applications : Drinking water supply networks, Hvac systems, irrigation, light industry.
- Fluids : water, non-aggressive fluids (compatibles EPDM / PTFE / brass), unlubricated compressed air (8 bar maxi).
- Pressure : PN32 / PN25 (according to the size).
- Temperatures : -10°C / +120°C (+90°C in continuous).

## Condiciones de uso

- Aplicaciones : Abastecimiento de agua potable, sistemas de calefacción y de climatización, irrigación, industria ligera.
- Fluidos : agua, fluidos no agresivos (compatibles EPDM / PTFE / latón), aire comprimido sin aceite (8 bar maxi).
- Presión : PN32 / PN25 (según el tamaño).
- Temperaturas : -10°C / +120°C (+90°C en continuado).

## Instructions d'utilisation

- Respecter les règles de l'art (ex : DTU) et les exigences réglementaires.
- Le réseau doit être exempt de toute impureté.
- Les conduites amont / aval doivent être parfaitement alignées et l'écartement doit être adapté à l'encombrement de la vanne.
- Appliquer un couple de serrage modéré.
- Utiliser des fluides compatibles et non corrosifs.
- Manipuler la vanne au moins 2 fois par an.
- L'utilisation de filasse n'est pas recommandée. Le cas échéant, ne pas charger excessivement le filet et réduire le couple de serrage.

## Instructions of use

- Respect the professional standards and regulatory requirements.
- The pipes must be free of any impurities.
- The upstream / downstream pipes must be perfectly aligned and the distances must be adapted to the size of the valve.
- Apply a moderate tightening torque.
- Use compatible and non-corrosive fluids.
- Handle the valve at least twice a year.
- The use of hemp is not recommended. If necessary, do not overload the thread ends and reduce the tightening torque.

## Instrucciones de uso

- Respete las buenas prácticas y los requisitos reglamentarios.
- Las canalizaciones deben estar exentas de cualquier impureza.
- Las tuberías aguas arriba / aguas abajo deben estar perfectamente alineadas y la distancia debe adaptarse al tamaño de la válvula.
- Aplicar un par de apriete moderado.
- Utilice fluidos compatibles y no corrosivos.
- Manipule la válvula al menos dos veces al año.
- No se recomienda el uso de hilaza. Si es necesario, no sobrecargue la conexión roscada y reduzca el par de apriete.

Download the [complete N-SMART manual](#)

Descargar el [manual completo de N-SMART](#)

Télécharger la [notice complète N-SMART](#)

## Certifications

- ACS : Conformité aux arrêtés du 29 mai 1997 modifié et du 25 juin 2020 relatifs à la consommation humaine.

## Certifications

- ACS : Comply with French drinking water regulation.

## Certificaciones

- ACS : Según el decreto francés en relación con el consumo humano.



## Caractéristiques techniques

- Vanne à sphère en laiton matricé CW617N-4MS, nickelé sur les surfaces extérieures.
- Conçue, fabriquée et contrôlée selon la norme EN 13828.
- Étanchéité testée à 100%.
- Passage standard.
- Axe inéjectable.
- Étanchéité par double joint torique EPDM.
- Embouts taraudés et filetés selon norme ISO 228-1 (BSPP série Gaz).
- Poignée plate réversible avec indication du sens de manœuvre ON/OFF.
- Marquage et traçabilité (date de fabrication, PN, taille, ACS, EZFIT Smart).
- QR code sur poignée (accès aux fiches techniques et à la notice via un smartphone) et étiquette individuelle en 2 langues avec code barre.

## Technical features

- CW617N-4MS forged brass ball valve, nickel plated on outer surfaces.
- Designed, manufactured and controlled according to standard EN 13828.
- Tightness 100% tested.
- Standard bore.
- Anti blow-out stem.
- Tightness with 2 EPDM O-rings.
- Female and male threaded ends according to ISO 228-1 standard (BSPP).
- Reversible flat handle with operating direction ON/OFF.
- Marking and traceability (manufacturing date, PN, size, ACS, EZFIT Smart).
- QR code on handle (to access technical sheet and notice from a smartphone) and individual label in 2 languages with barcode.

## Características técnicas

- Válvula de esfera de latón forjado CW617N-4MS, nickelado en las superficies exteriores.
- Diseñada, fabricada y controlada según la norma EN 13828.
- Estanqueidad testada al 100%.
- Paso estándar.
- Eje anti-expulsión.
- Estanqueidad por doble junta tórica de EPDM.
- Conexión roscadas hembra y macho según la norma ISO 228-1 (BSPP).
- Palanca plana reversible con indicador de dirección ON/OFF.
- Identificación y trazabilidad (fecha de fabricación, PN, DN, ACS, EZFIT Smart).
- QR code en la palanca (acceso a las fichas técnicas y las instrucciones desde un smartphone) y etiqueta individual en 2 idiomas con código de barras.



## Nomenclature

## Parts list

## Lista de materiales

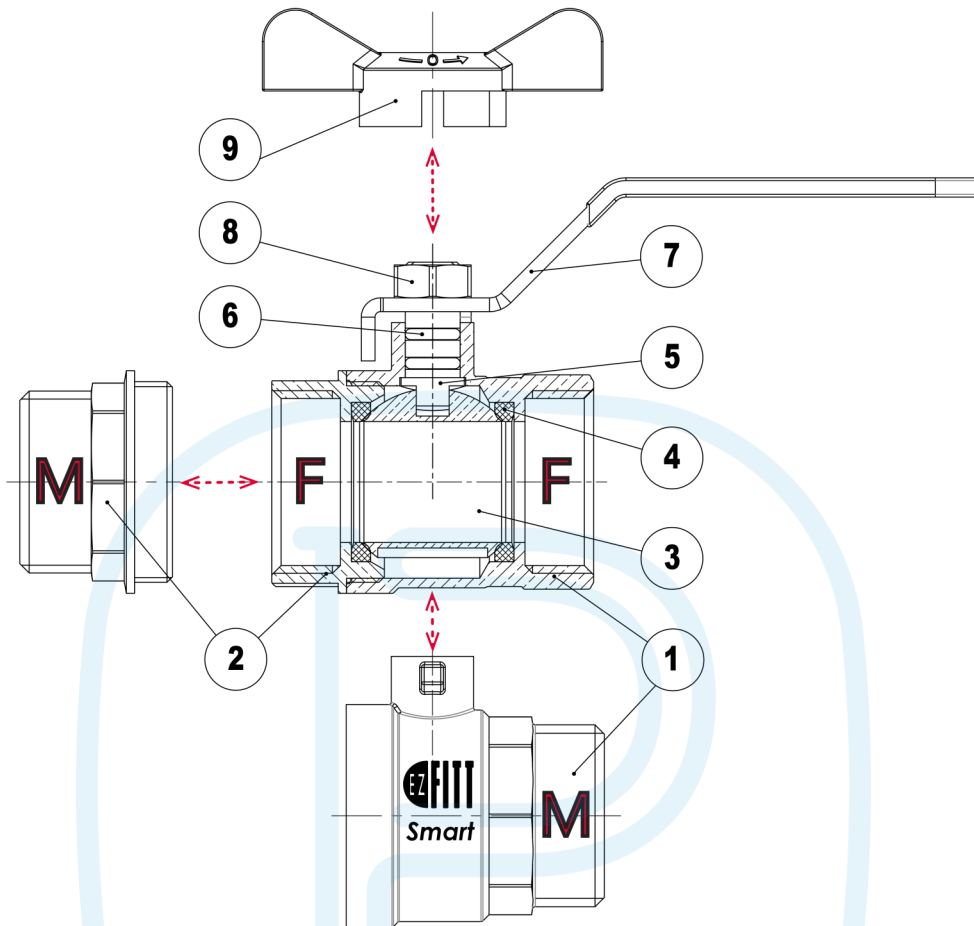

N°	Qté	Désignation	Matière	Description	Material	Descripción	Materia
1	1	Corps	Laiton matricé CW617N-4MS, surfaces extérieures nickelées	Body	CW617N-4MS forged brass, nickel plated on outer surfaces	Cuerpo	Latón forjado CW617N-4MS, superficies exteriores niqueladas
2	1	Manchon	Laiton matricé CW617N-4MS, surfaces extérieures nickelées	Bonnet	CW617N-4MS forged brass, nickel plated on outer surfaces	Tapa	Latón forjado CW617N-4MS, superficies exteriores niqueladas
3	1	Sphère	Laiton CW617N chromé ou Inox 304 à partir de la taille 1"1/4	Ball	Chrome plated CW617N brass or SS 304 from size 1"1/4	Esfera	Latón CW617N cromado o acero inoxidable 304 desde tamaño 1"1/4
4	2	Siège	PTFE	Seat	PTFE	Asiento	PTFE
5	1	Axe	Laiton CW617N-4MS	Stem	CW617N-4MS brass	Eje	Latón CW617N-4MS
6	2	Joint torique	EPDM	O-ring	EPDM	Junta tórica	EPDM
7	1	Poignée plate	Acier revêtu zinc-aluminium noir + PVC	Flat handle	Black zinc-aluminium coated steel + PVC	Palanca plane	Acero recubrimiento de zinc-aluminio negro + PVC
8	1	Écrou (ou vis + rondelle)	Acier nickelé	Nut (or screw + washer)	Nickel plated steel	Tuerca (o tornillo + arandela)	Acero niquelado
9	1	Poignée papillon	Aluminium peint	Butterfly handle	Painted aluminum	Palanca mariposa	Aluminio pintado

Dimensions et données techniques

Dimensions and technical data

Dimensiones y datos técnicos

### Art. 120 - Art. 120 PB

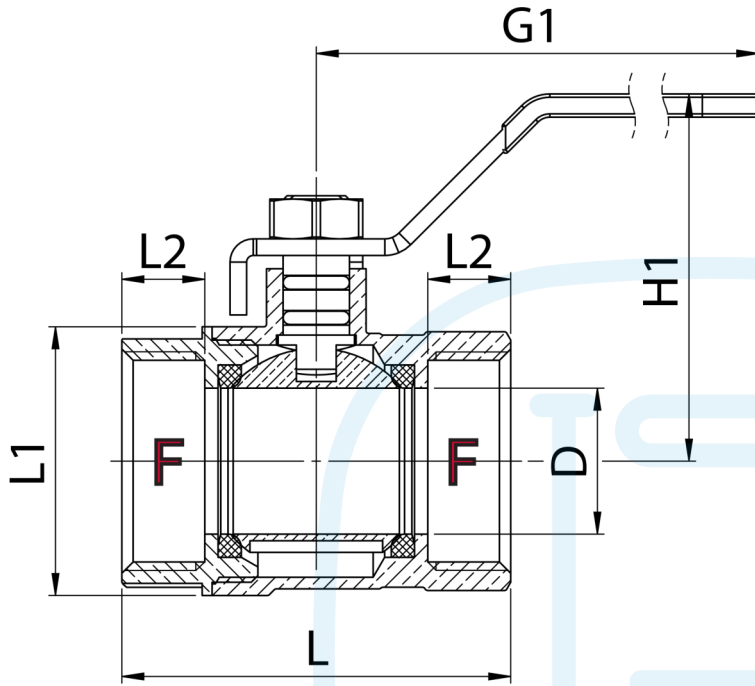

### Art. 123

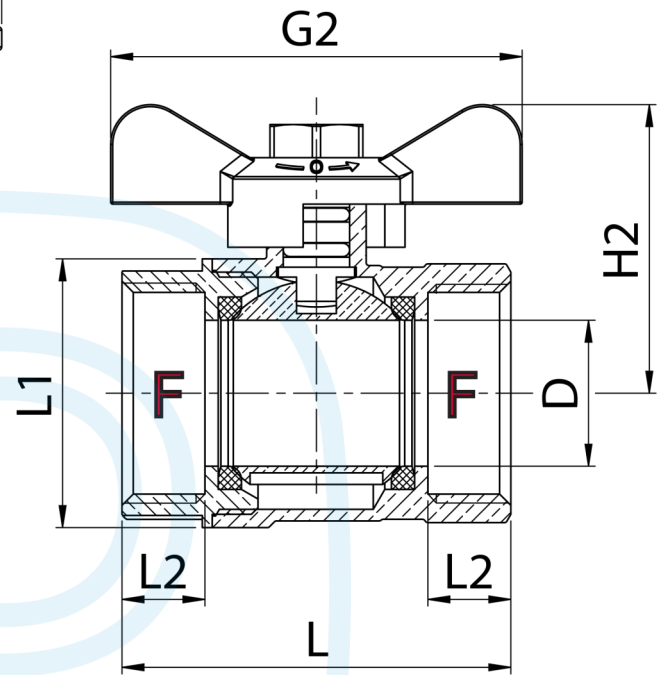

Ø	PN (bar)	D	L	L1	L2	Art. 120 - Art.120 PB				Art. 123			
						Ref.	G1	H1	kg	Ref.	G2	H2	kg
3/8"	32	10	37.5	23	8.5	19201 - 19201PB	77	40	0.100	19231	44	30	0.078
1/2"	32	13.5	42	27	9.5	19202 - 19202PB	85	43	0.133	19232	44	34	0.111
3/4"	32	18	48	33	10	19203 - 19203PB	85	46	0.184	19233	53	37	0.162
1"	32	22	59	40	12.5	19204 - 19204PB	104	55	0.302	19234	63	44.5	0.274
1"1/4	25	28	66	49.5	13	19205 - 19205PB	130	69	0.465	-	-	-	-
1"1/2	25	35	80	60.5	14.5	19206 - 19206PB	130	75	0.673	-	-	-	-
2"	25	45	94	75.5	16	19207 - 19207PB	156	85	1.058	-	-	-	-

Dimensions et données techniques

Dimensions and technical data

Dimensiones y datos técnicos

### Art. 121 - Art. 121 PB

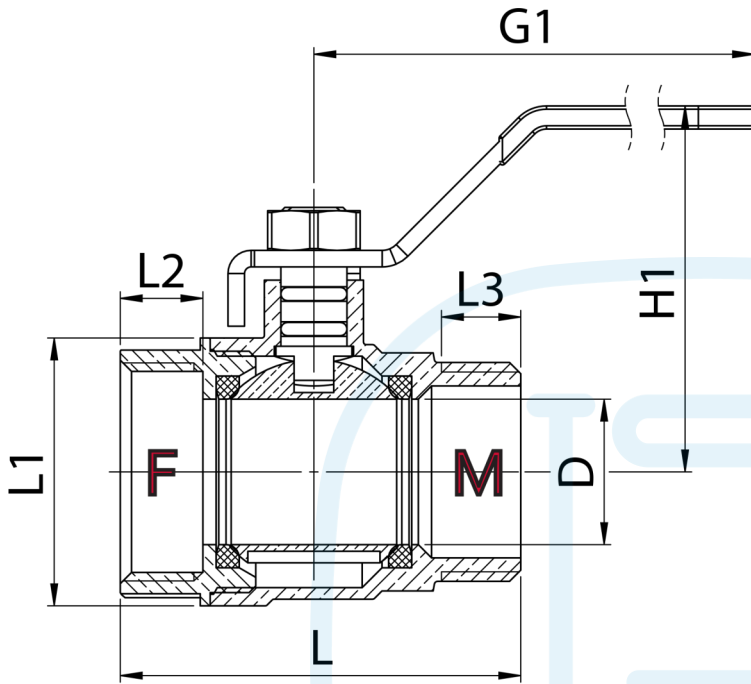

### Art. 124

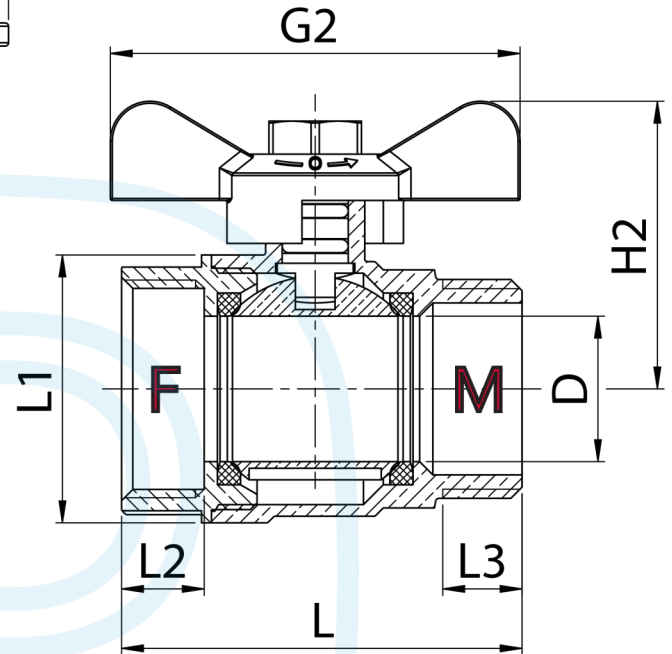

Ø	PN (bar)	D	L	L1	L2	L3	Art. 121 - Art.121 PB			Art. 124				
							Ref.	G1	H1	kg	Ref.	G2	H2	kg
3/8"	32	10	40	23	8.5	8.5	19211 - 19211PB	77	40	0.103	19241	44	30	0.081
1/2"	32	13.5	45	27	9.5	10.5	19212 - 19212PB	85	43	0.137	19242	44	34	0.115
3/4"	32	18	50.5	33	10	11.5	19213 - 19213PB	85	46	0.186	19243	53	37	0.164
1"	32	22	61	40	12.5	13	19214 - 19214PB	104	55	0.303	19244	63	44.5	0.274
1"1/4	25	28	68	49.5	13	14	19215 - 19215PB	130	69	0.465	-	-	-	-
1"1/2	25	35	83	60.5	14.5	15.5	19216 - 19216PB	130	75	0.673	-	-	-	-
2"	25	45	96	75.5	16	17	19217 - 19217PB	156	85	1.066	-	-	-	-

### Art. 122 - Art. 122 PB

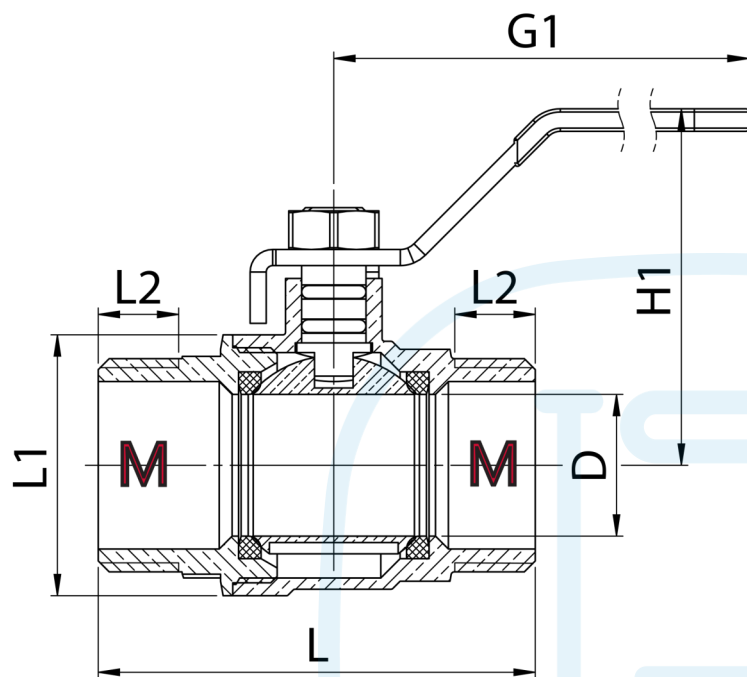

### Art. 125

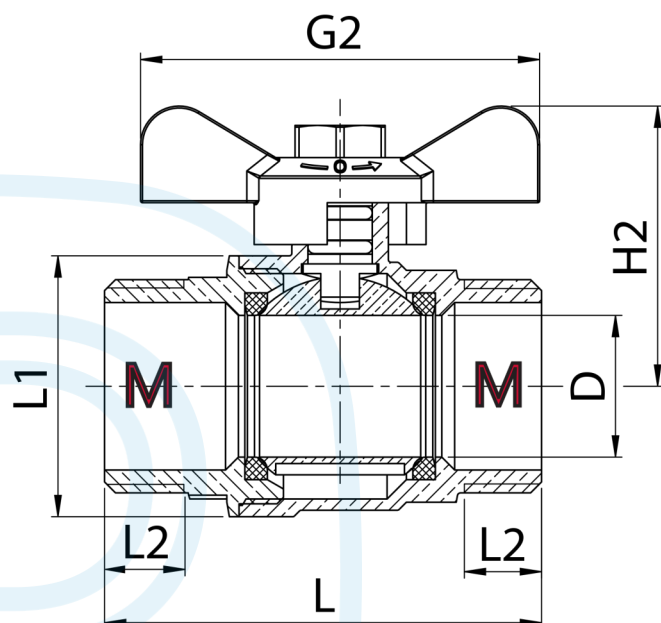

Ø	PN (bar)	D	L	L1	L2	Art. 122 - Art.122 PB				Art. 125			
						Ref.	G1	H1	kg	Ref.	G2	H2	kg
3/8"	32	10	47	23	8.5	19221 - 19221PB	77	40	0.111	19251	44	30	0.089
1/2"	32	13.5	52.5	27	10.5	19222 - 19222PB	85	43	0.147	19252	44	34	0.125
3/4"	32	18	57	33	11.5	19223 - 19223PB	85	46	0.196	19253	53	37	0.173
1"	32	22	68	40	13	19224 - 19224PB	104	55	0.322	19254	63	44.5	0.293

**Graphique Pression/Température** Pressure/Temperature chart

**Gráfico Presión/Temperatura**

Graphique à titre indicatif  
 Fluide : eau

Chart for information purposes  
 Fluid : water

Gráfico a título informativo  
 Fluido : agua

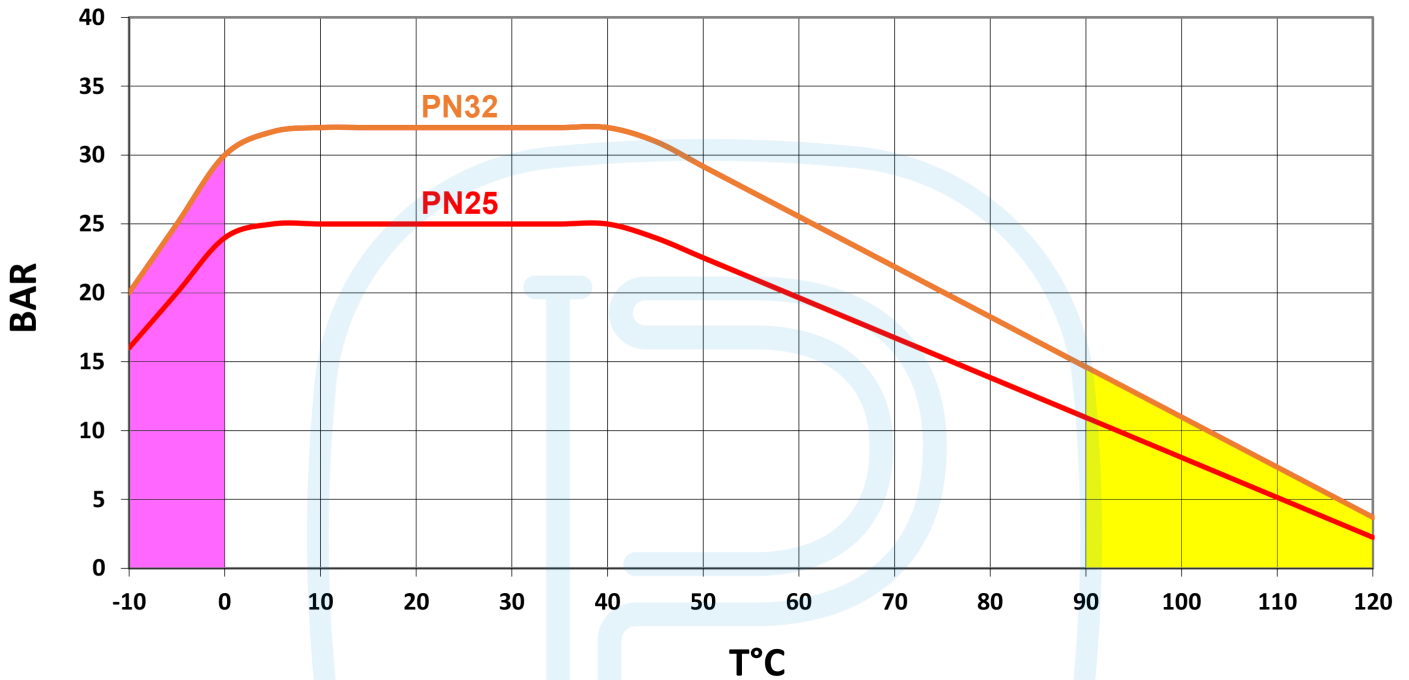

- |   |  |  |
|---|--|--|
| <p> Zone d'utilisation en pointe sur une courte durée.<br/>Non compatible pour la vapeur.</p> | <p>Use area for peak temperature in a short time.<br/>Not suitable with steam.</p> | <p>Área de uso para temperatura máxima por un período corto.<br/>No compatible para vapor.</p> |
| <p> Zone d'utilisation avec eau glycolée.<br/>Maintenir la vanne hors gel.</p>                | <p>Use area with glycol water.<br/>Keep the valve frost-free.</p>                  | <p>Área de uso con agua glicolada.<br/>Mantenga la válvula libre de congelación.</p>           |