

## 4" Submersible motors L4C Series

Submersible water filled encapsulated motors.



### SPECIFICATIONS

- Stainless steel outer sleeve.
- Shaft extension and coupling dimensions to **NEMA** standards.
- **Class insulation:** 155 (F).
- **Protection class:** IP68.
- Internal fluid suitable for contact with foodstuffs.
- Strong and durable compensating bellows.
- Axial load supported by angular bearings.
- Mechanical seal protected by sand guard.
- **Maximum immersion depth:** 300 m.
- Suitable for both vertical / horizontal installations
- **Maximum number of starts per hour at regular intervals:** 40 for direct start; 20 for impedance start.
- **Maximum water temperature:** 35°C.  
Max. temperature applies to motors working in a installation capable of delivering a flow of water around the motor jacket of at least 0,3 m/s.
- **Axial thrust:** 2000 N from 0,37 to 1,1 kW; 3000 N from 1,5 to 2,2 kW; 6000 N from 3 to 7,5 kW.

### • Versions:

- Single-phase:  
from 0,37 to 4 kW  
(until 1,1 kW with built in automatic reset overload protection).  
220-240 V ± 6% 50 Hz
- Three-phase:  
from 0,37 to 5,5 kW  
220-240 V ± 6% 50 Hz  
from 0,37 to 7,5 kW  
380-415 V ± 6% 50 Hz

### OPTIONAL FEATURES

- Different voltages and frequencies
- Single-phase version up to 1,1 kW with built-in capacitor and motor protection (2W = Two Wire).
- Upper support with customized material.

For application limits, refer to technical appendix chapter.

### ACCESSORIES

- Control panels.
- Drop cables.
- Coupling flanges.
- Cooling sleeves.
- Capacitors.

- **High starting torque**
- **Power supply cable with extractable connector**
- **Mechanical seal**
- **Kingsbury type thrust bearing**
- **Screws to fix the pump are included**

## L4C MOTOR SERIES MOTOR CROSS SECTION AND TABLE OF MATERIALS

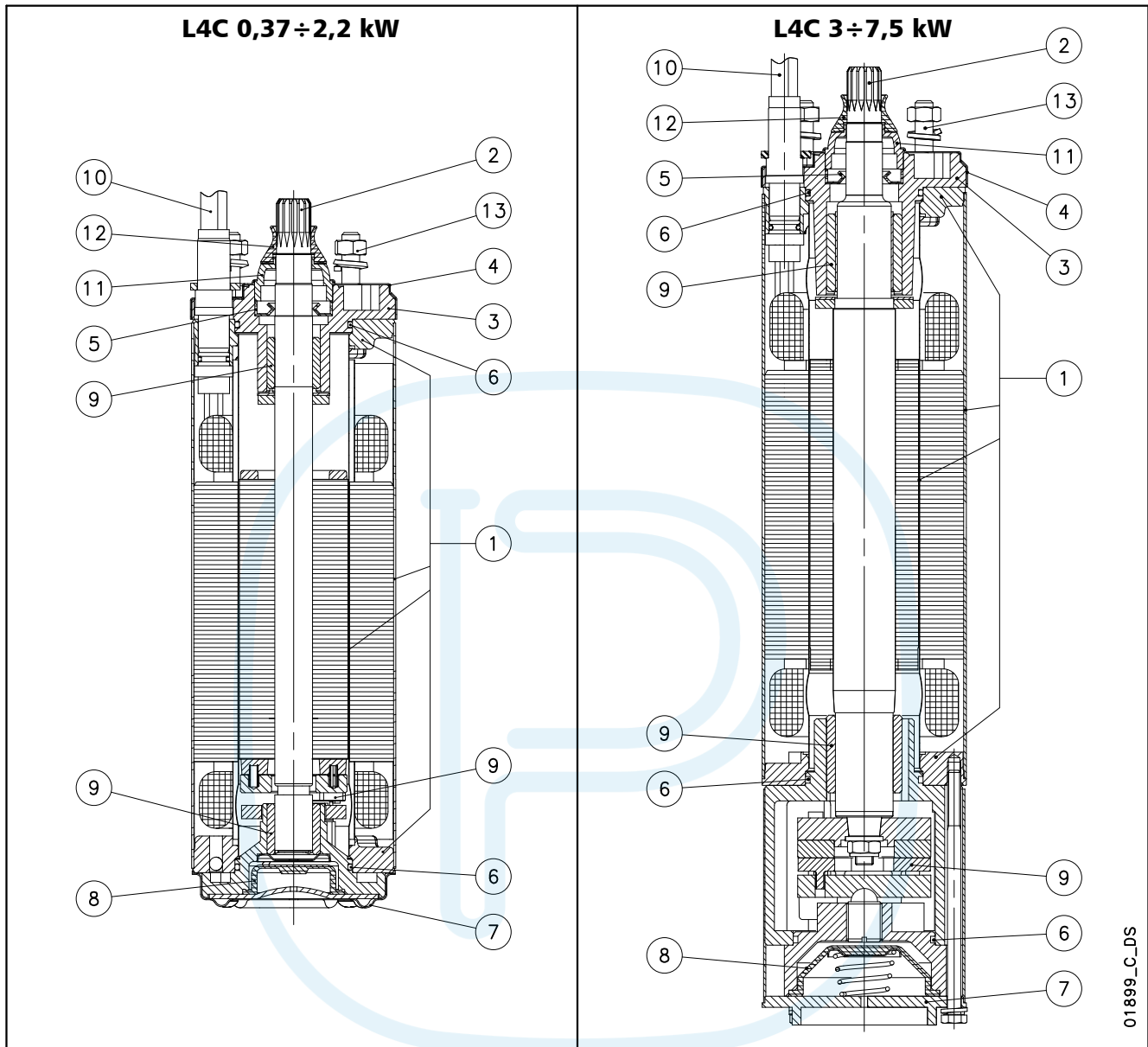

01899\_C\_DS

REF N°	PART	MATERIAL	DESIGNATION	
			EUROPE	USA
1	Inner, outer sleeves and flanges	Stainless steel	EN 10088-1-X2CrNi18-9 (1.4307)	AISI 304L
2	Shaft extension (up to 2.2 kW)	Stainless steel	EN 10088-1-X5CrNi18-10 (1.4301)	AISI 304
	Shaft extension (from 3 kW)	Stainless steel	EN 10088-3-X3CrNiMoN27 (1.4460)	AISI 329
3	Upper bracket	Cast iron	EN 1561-EN-GJL-200 (EN-JL1030)	Class 25 B
4	Upper cover	Stainless steel	EN 10088-1-X5CrNi18-10 (1.4301)	AISI 304
5	Lip seal	NBR		
6	Elastomers	NBR		
7	Lower cover (up to 2.2 kW)	Stainless steel	EN 10088-1-X5CrNi18-10 (1.4301)	AISI 304
	Lower cover (from 3 kW)	Cast iron	EN 1561-EN-GJL-200 (EN-JL1030)	Class 25 B
8	Compensating bellows	EPDM		
9	Bearings	Carbon-graphite		
10	Cable	EPDM		
11	Fixed sand guard	PA6		
12	Removable sand guard	NBR		
13	Bolts and screws	Stainless steel	EN ISO 3506-1 Grade A2	
-	Cooling liquid	Demineralized water + antifreeze		

## L4C MOTOR SERIES DIMENSIONS AND WEIGHTS AT 50 Hz

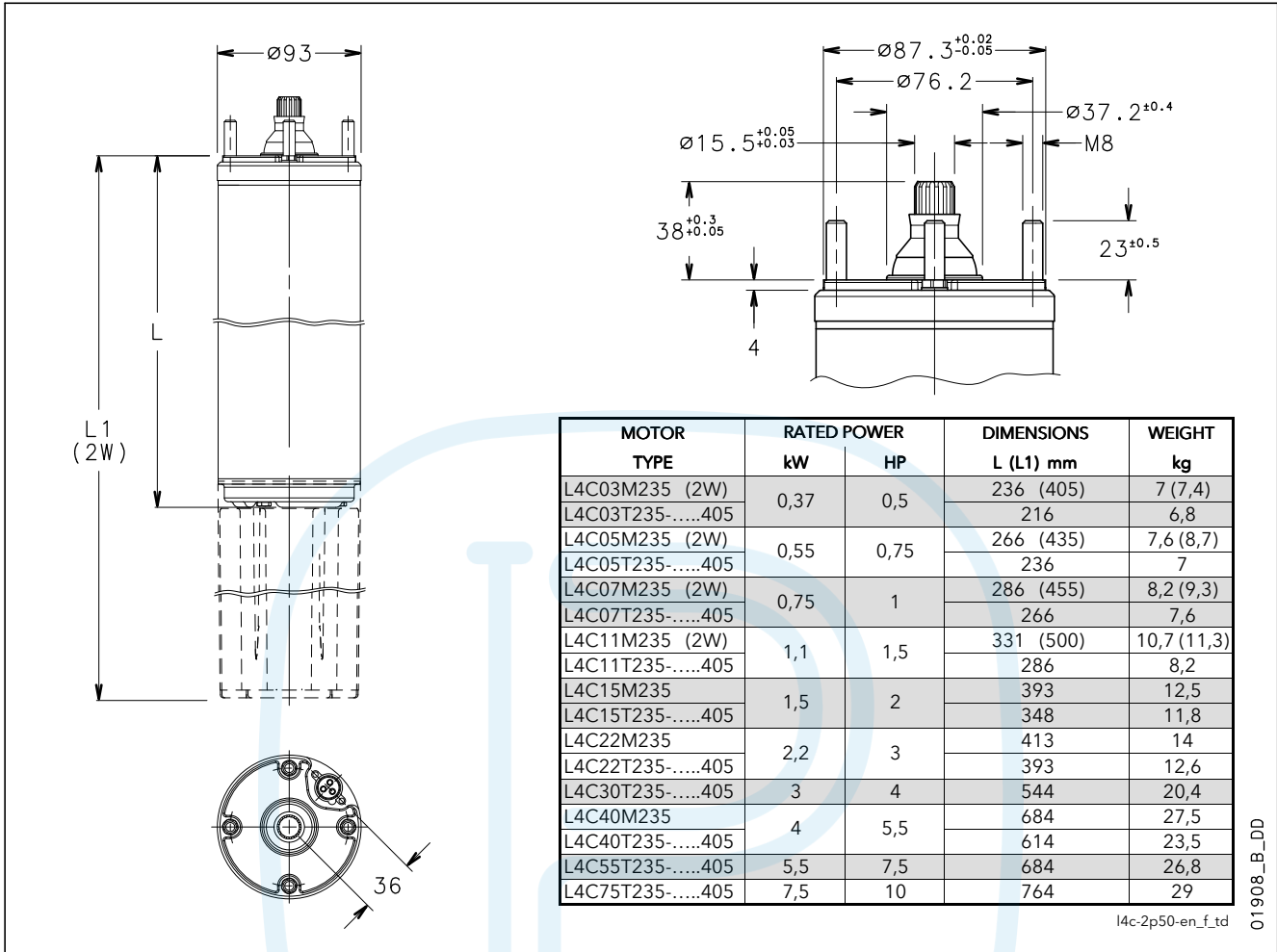

## SINGLE-PHASE OPERATING CHARACTERISTICS AT 50 Hz

MOTOR TYPE	RATED POWER		RATED VOLTAGE	RATED CURRENT	CAPACITOR	OPERATING CHARACTERISTICS AT RATED POWER			DIRECT START		MAX WATER TEMPERATURE	CABLE TYPE (FLAT)	
	kW	HP				rpm	η %	cos φ	Ts/Tn	Is/In		°C	4G ... * mm <sup>2</sup>
L4C03M235*	0,37	0,5	220	3,2	16	2810	53	0,96	0,63	2,68	35	1,5	1,7
			230	3,3		2820	54	0,97	0,69	2,72			
			240	3,4		2830	50	0,91	0,75	2,76			
L4C05M235*	0,55	0,75	220	4,3	20	2810	61	0,95	0,62	3,3	35	1,5	1,7
			230	4,6		2820	56	0,94	0,68	3,2			
			240	4,8		2830	54	0,90	0,74	3,26			
L4C07M235*	0,75	1	220	6	30	2810	60	0,93	0,63	3,18	35	1,5	1,7
			230	6,2		2820	58	0,92	0,66	3,2			
			240	6,5		2830	56	0,85	0,75	3,2			
L4C11M235*	1,1	1,5	220	8	40	2820	67	0,94	0,60	3,48	35	1,5	1,7
			230	8,1		2835	65	0,92	0,60	3,54			
			240	8,3		2850	63	0,87	0,62	3,62			
L4C15M235	1,5	2	220	10,4	50	2800	67	0,96	0,74	3,3	35	1,5	1,7
			230	10,4		2820	66	0,93	0,74	3,38			
			240	10,7		2835	64	0,90	0,76	3,46			
L4C22M235	2,2	3	220	15,4	70	2740	68	0,96	0,54	3,1	35	1,5	1,7
			230	15		2770	68	0,94	0,54	3,2			
			240	15,3		2790	66	0,91	0,54	3,3			
L4C40M235	4	5,5	220	29,9	90	2820	70	0,93	0,46	3,5	35	2	2,7
			230	29,8		2830	68	0,90	0,51	3,6			
			240	29,7		2840	65	0,87	0,60	3,4			

Ts/Tn = ratio between starting torque and nominal torque.

Is/In = ratio between starting current and nominal current

l4cm-2p50-en\_h\_te

\* Cable 3G for models L4C03M235/2W, L4C05M235/2W, L4C07M235/2W, L4C11M235/2W

## L4C MOTOR SERIES THREE-PHASE OPERATING CHARACTERISTICS AT 50 Hz

MOTOR TYPE	RATED POWER		RATED VOLTAGE	RATED CURRENT	OPERATING CHARACTERISTICS AT RATED POWER			DIRECT STARTING		MAX WATER TEMPERATURE	CABLE TYPE (FLAT)	
	kW	HP			V	A	rpm	$\eta$ %	$\cos\phi$		Ts/Tn	Is/In
L4C03T235	0,37	0,5	220	2,6	2810	51	0,69	2,7	3,7	35	1,5	1,7
			230	2,7	2820	53	0,7	3	3,7			
			240	3,1	2830	48	0,67	3,2	3,4			
L4C05T235	0,55	0,75	220	3,1	2820	61	0,77	2,8	4,3	35	1,5	1,7
			230	3,3	2830	60	0,71	3,1	4,2			
			240	3,5	2840	60	0,66	3,3	4,2			
L4C07T235	0,75	1	220	4	2820	65	0,77	2,9	5	35	1,5	1,7
			230	4,1	2830	63	0,73	3,2	5,1			
			240	4,5	2840	63	0,66	3,5	4,8			
L4C11T235	1,1	1,5	220	5,6	2820	62	0,8	3	4	35	1,5	1,7
			230	5,7	2830	64	0,76	3,3	4,2			
			240	6,2	2840	63	0,73	3,6	4			
L4C15T235	1,5	2	220	7,4	2820	68	0,77	3,1	4,2	35	1,5	1,7
			230	7,6	2830	68	0,72	3,4	4,3			
			240	8	2840	67	0,68	3,7	4,3			
L4C22T235	2,2	3	220	10	2810	72	0,8	3	4,3	35	1,5	1,7
			230	10,2	2820	71	0,78	3,2	4,4			
			240	10,7	2830	70	0,7	3,5	4,4			
L4C30T235	3	4	220	13,7	2830	75	0,77	3	4,6	35	1,5	2,7
			230	14,3	2840	74	0,71	3,3	4,6			
			240	15,2	2850	70	0,68	3,5	4,5			
L4C40T235	4	5,5	220	16,4	2840	76	0,81	3,10	5,6	35	2	2,7
			230	17,3	2850	75	0,79	3,40	5,6			
			240	18,2	2860	72	0,74	3,70	5,5			
L4C55T235	5,5	7,5	220	23,4	2840	78	0,79	3	5,4	35	2	2,7
			230	24,2	2850	77	0,74	3,4	5,5			
			240	25	2860	76	0,7	3,6	5,5			
L4C03T405	0,37	0,5	380	1,5	2810	51	0,69	2,7	3,8	35	1,5	1,7
			400	1,6	2820	53	0,7	3	3,8			
			415	1,8	2830	48	0,67	3,2	3,4			
L4C05T405	0,55	0,75	380	1,8	2820	61	0,77	2,8	4,2	35	1,5	1,7
			400	1,9	2830	60	0,71	3,1	4,2			
			415	2	2840	60	0,66	3,3	4,1			
L4C07T405	0,75	1	380	2,3	2820	65	0,77	2,9	5	35	1,5	1,7
			400	2,4	2830	63	0,73	3,2	5			
			415	2,6	2840	63	0,66	3,5	4,8			
L4C11T405	1,1	1,5	380	3,3	2820	62	0,8	3	4	35	1,5	1,7
			400	3,4	2830	64	0,76	3,3	4,1			
			415	3,6	2840	63	0,73	3,6	4			
L4C15T405	1,5	2	380	4,3	2820	68	0,77	3,1	4,2	35	1,5	1,7
			400	4,4	2830	68	0,72	3,4	4,3			
			415	4,6	2840	67	0,68	3,7	4,3			
L4C22T405	2,2	3	380	5,8	2810	72	0,8	3	4,1	35	1,5	1,7
			400	5,9	2820	71	0,78	3,2	4,4			
			415	6,2	2830	70	0,7	3,5	4,3			
L4C30T405	3	4	380	7,9	2830	75	0,77	3	4,5	35	1,5	2,7
			400	8,3	2840	74	0,71	3,3	4,6			
			415	8,8	2850	70	0,68	3,5	4,5			
L4C40T405	4	5,5	380	9,5	2840	76	0,81	3,1	5,6	35	1,5	2,7
			400	10	2850	75	0,79	3,4	5,6			
			415	10,5	2860	72	0,74	3,7	5,5			
L4C55T405	5,5	7,5	380	13,5	2840	78	0,79	3	5,4	35	1,5	2,7
			400	14	2850	77	0,74	3,4	5,5			
			415	14,5	2860	76	0,7	3,6	5,5			
L4C75T405	7,5	10	380	17	2840	80	0,84	2,6	4,7	35	2	3,5
			400	17,4	2850	79	0,79	2,9	4,8			
			415	18,1	2860	76	0,75	3,1	4,8			

Ts/Tn = ratio between starting torque and nominal torque.

Is/In = ratio between starting current and nominal current

l4ct-2p50-en\_d\_te